

A white five-pointed star with a long tail pointing towards the top-left corner of the slide.

# Edge Matching of National INSPIRE Datasets at European State Boundaries

Marcus Brühl, Federal Agency for Cartography and Geodesy (BKG), Germany  
Powered by INSPIRE, Brussels March 2013

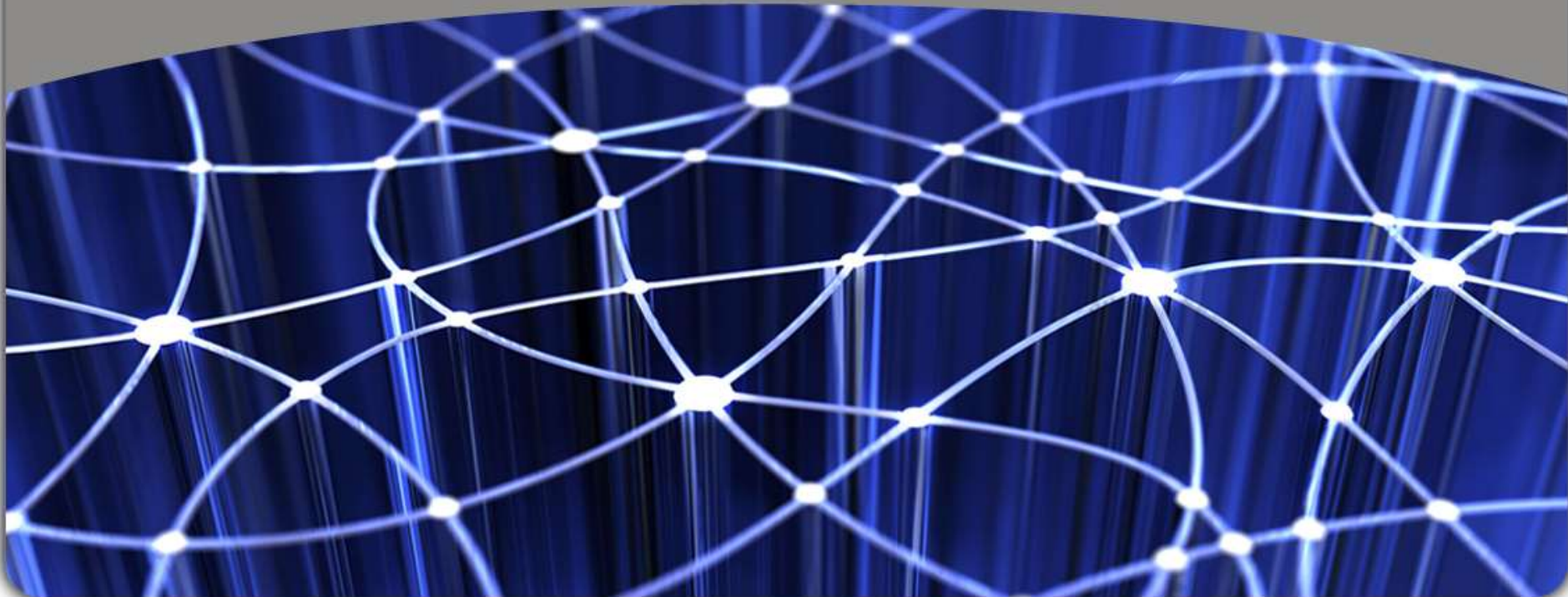

- Challenges of INSPIRE implementation
- State Boundaries of Europe (SBE)
- Edge matching

## EuroGeographics AISBL

- Membership association comprising public authorities responsible for national cadastre, land registry and mapping (e.g. BKG)
- Purpose: further the development of the European Spatial Data Infrastructure through collaboration in the area of geographic information and the representation of the EuroGeographics' membership and its capabilities

# Challenges of INSPIRE implementation



- Focus of national INSPIRE implementation:
    - Identification of national datasets which have to be considered for INSPIRE
    - Setting of INSPIRE compliant services on national datasets
    - Schema transformation of national datasets to INSPIRE data specifications
  - Challenges:
    - Boundaries (outlines) of national datasets
    - Level of detail (scale)
    - Edge matching of features across boundaries
- Not focused by the the National Mapping and Cadastre Agencies up to now

# Challenges of INSPIRE implementation

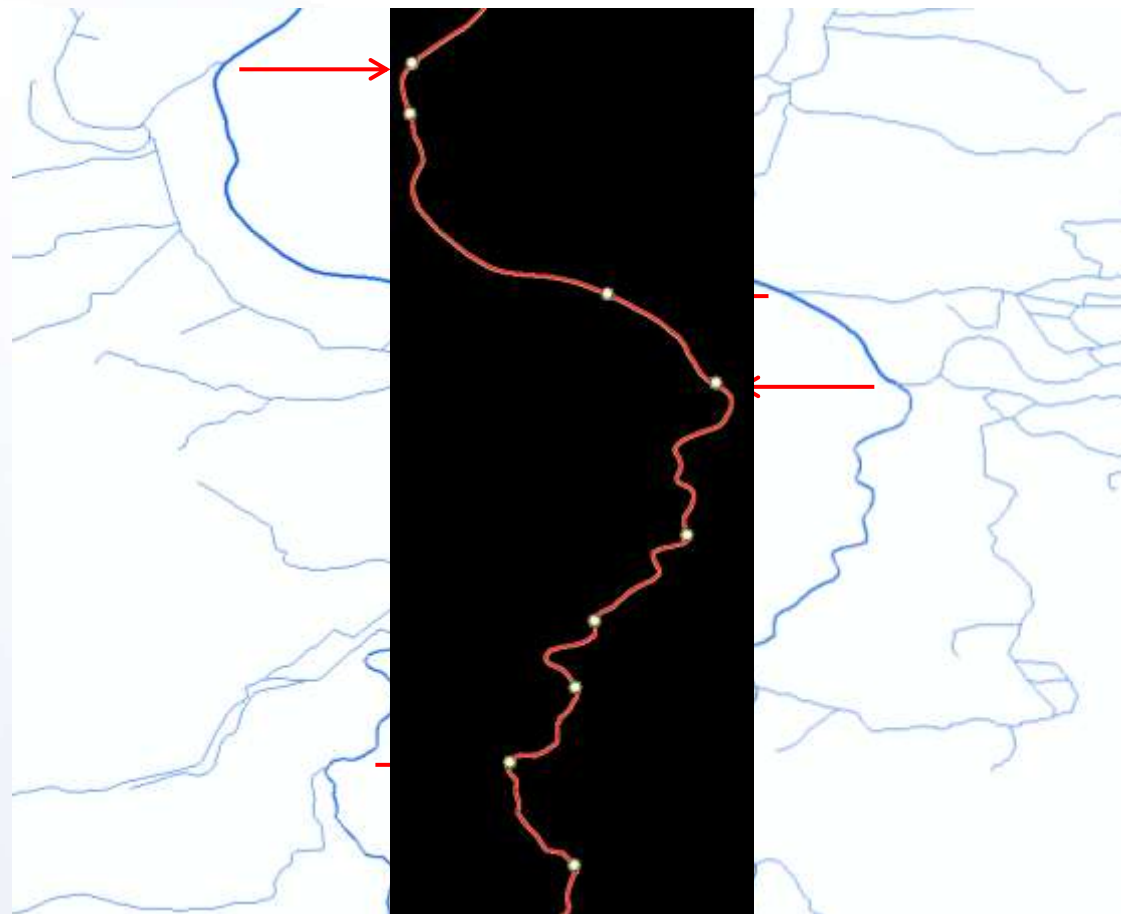

German watercourse network

Polish watercourse network

Regional level of detail (medium scale)

To benefit from  
different national  
INSPIRE datasets in  
pan-European  
context



Edge matching  
of national features  
to agreed state  
boundaries needed

# State Boundaries of Europe (SBE)



- Project launched by EuroGeographics
- Goal: to compile a multipurpose State Boundaries of Europe database, meant to be the “definite” description of all European state boundaries.
- The SBE project aims at providing and maintaining:
  - The administrative and legal definition of state boundaries, based on boundary treaties,
  - Their precise geometric description expressed in ETRS89 coordinates of boundary points, marks and lines,
  - Generalised versions of the state boundaries in different levels of detail.



# State Boundaries of Europe (SBE)



- SBE will be realised for different levels of detail:

<b>Level of detail</b>	<b>Scale</b>	<b>Type of data</b>	<b>Realisation</b>
Treaty level	cadastre scale	high precision coordinates of boundary points and lines	long-term
Master data level	1:10' to 1:50'	large scale boundary lines from national basic cadastral or topographic database	medium-term (E.L.F. project)
Regional level	1:100' to 1:250'	agreed state boundaries for use at medium scale	first version available
Global level	1:500' to 1:2 M	generalised version	(end 2013)

- Why is it so difficult to get the legal definition of state boundaries?
  - Definitions of state boundaries are laid down in historical documents.
  - Coordinates, if included, are difficult to transform to ETRS89.
  - New surveying campaigns are costly and time-consuming.
  - Bilateral negotiations are time-consuming and influenced by complex technical issues.
  - Some European state boundaries are in dispute.
- Short-term realisation: SBE database in regional level of detail
  - Derived from existing European reference databases: EuroBoundaryMap (EBM) and EuroRegionalMap (ERM).
  - EBM and ERM are compiled from the medium scale topographic databases of the national mapping agencies (official data).
  - State boundaries are agreed for EBM and ERM as technical solution for use at medium scale.
  - Remaining issues will be clarified in 2013.

- Definition in the scope of INSPIRE:

Edge matching comprises all process steps needed to combine INSPIRE datasets (especially topographic reference data) made accessible by different data providers via INSPIRE services to pan-European datasets, in order to achieve geometrical, topological and semantic cross-boundary consistency.

- EuroGeographics concept: Connecting Features on the State Boundaries

- Connecting features represent locations on the state boundaries where edge matched geographic entities from neighbouring countries connect.
- Connecting features serve as anchor for repeatable edge matching.
- First realisation for regional level of detail, derived from existing European reference databases EBM and ERM.



# Edge matching

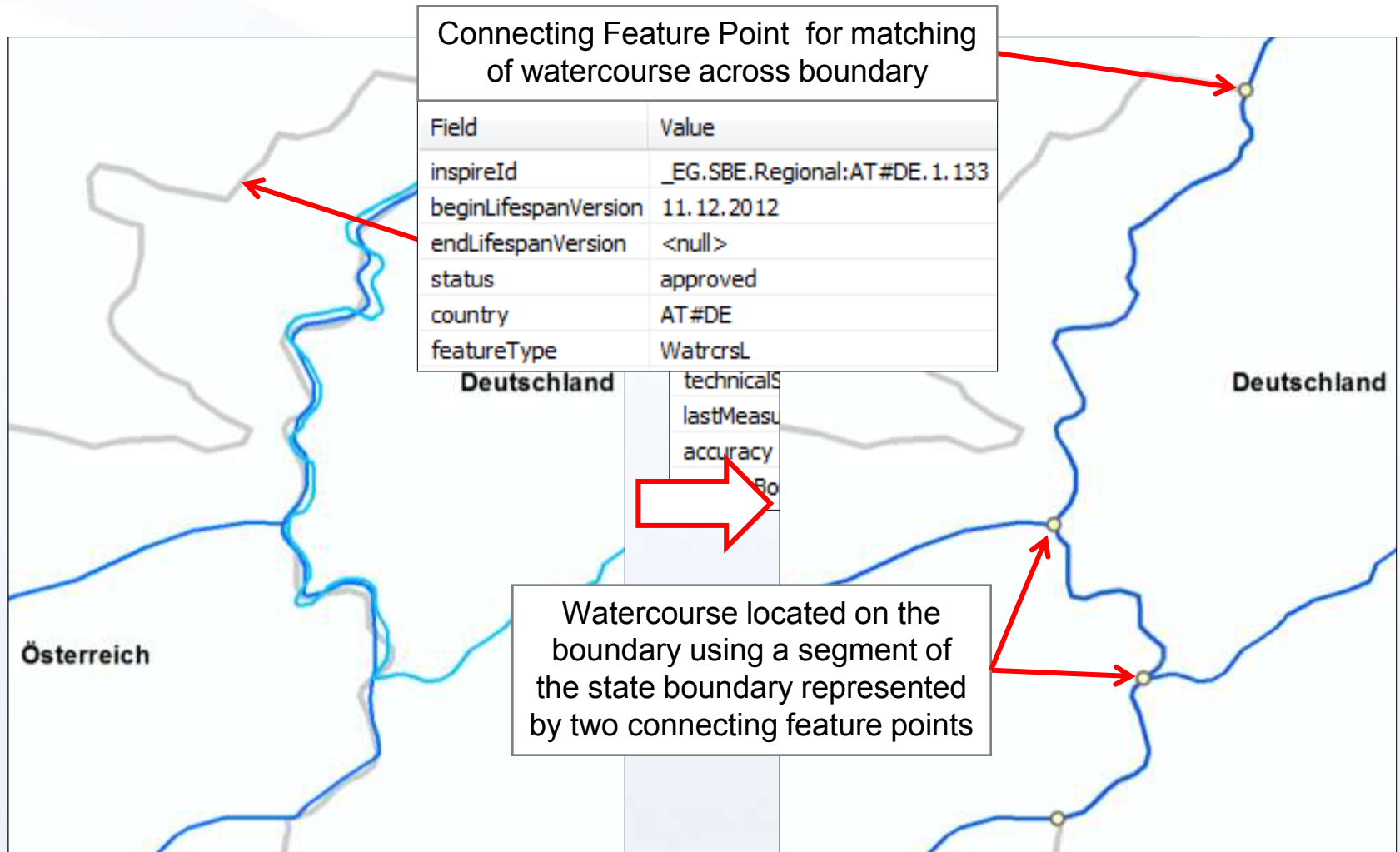

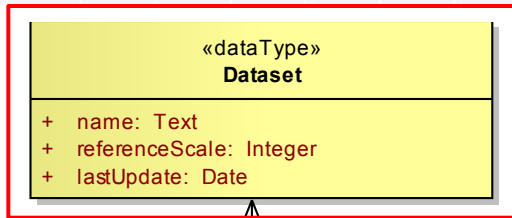

Metadata  
(level of detail)  
State boundaries:  
based on INSPIRE feature type  
AdministrativeBoundary,  
additional attributes

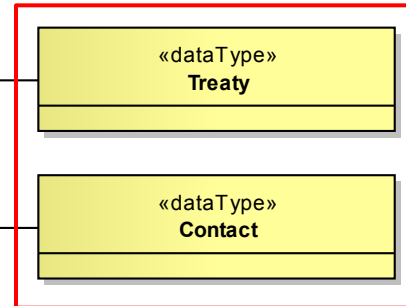
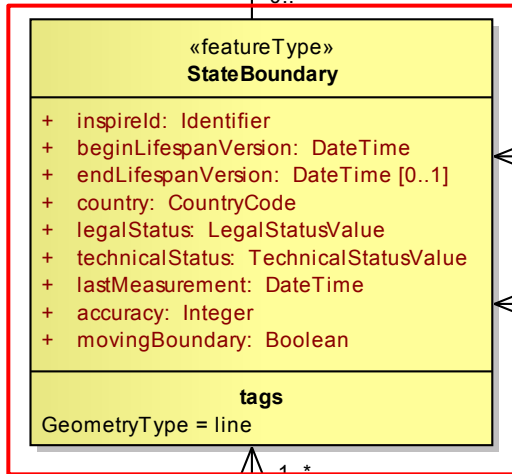

## Data model of SBE database for edge matching

Metadata:  
information about  
boundary treaties  
and point of contact

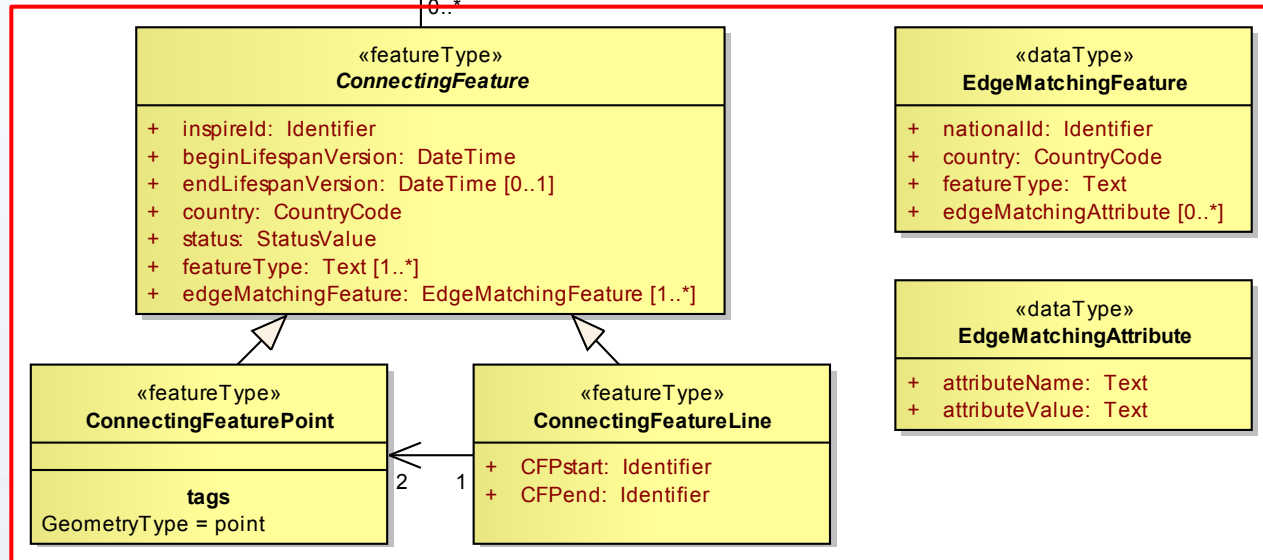

Edge matching  
concept:  
connecting features  
and link to national  
objects by inspireId

## Next steps



- Make SBE Regional Level available for a broader audience
- Compile SBE database for other level of detail (master data level)
- Set up web service (web tool) for automatic edge matching  
(→ E.L.F. project)

- Edge matching to agreed state boundaries is necessary to use different national INSPIRE datasets in pan-European context.
- SBE project will provide the legal definition of state boundaries in different levels of detail and additional connecting features to support edge matching.
- First realisation for European coverage is SBE in regional level of detail.

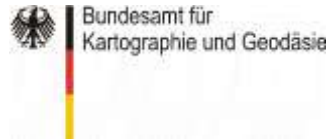

Marcus Brühl / BKG:

[marcus.bruehl@bkg.bund.de](mailto:marcus.bruehl@bkg.bund.de)



State Boundaries of Europe (SBE), EBM, ERM

[www.eurogeographics.org/sbe](http://www.eurogeographics.org/sbe)

[www.eurogeographics.org/products-and-services](http://www.eurogeographics.org/products-and-services)



Edge matching concept (ESDIN project)

[http://www.esdin.eu/sites/esdin.eu/files/D9.1\\_EdgeMatching-ProcessSpec\\_v1.0.pdf](http://www.esdin.eu/sites/esdin.eu/files/D9.1_EdgeMatching-ProcessSpec_v1.0.pdf)

→ E.L.F. Project (start 03/2013)